



**CASE STUDY:
METROPOLITAN POLICE FLEET SERVICES
REPAIR AND MAINTENANCE CENTRE**

WORLD-CLASS WORKSHOPS TO KEEP THE MET MOVING

The Metropolitan Police's extensive fleet of vehicles is key to their success in keeping London safe. Acknowledging Dura's track record for providing outstanding workshops for both commercial and emergency service clients, the Met approached the team through a distributor partner to provide custom-designed furniture for their new 40,000 sq ft vehicle repair and maintenance facility.



Complete service integration

THE BACKGROUND

As the police force for the UK's capital, the Metropolitan Police (Met) has a unique set of responsibilities and challenges. It polices 620 square miles and serves more than eight million people across one of the world's most dynamic and diverse cities. As part of this role it protects over 160 foreign embassies and high commissions, polices Heathrow (Europe's busiest airport), while also dealing with thousands of protests and special events every year, significantly more than any other force in the country.

To tackle this huge responsibility, the Met needs to maintain a large fleet of vehicles, from motorcycles and patrol cars, to armoured vehicles. Dura was privileged to be approached directly through its distributor partner, CES, to help create a world-class repair and maintenance facility to rise to this exceptional challenge.

THE PLAN

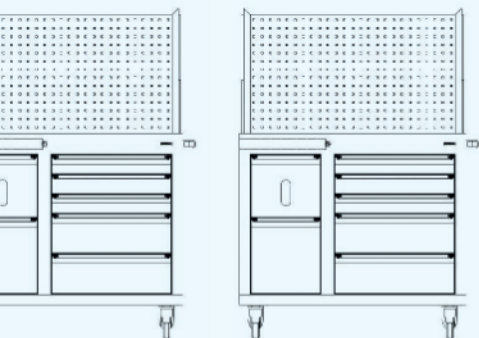
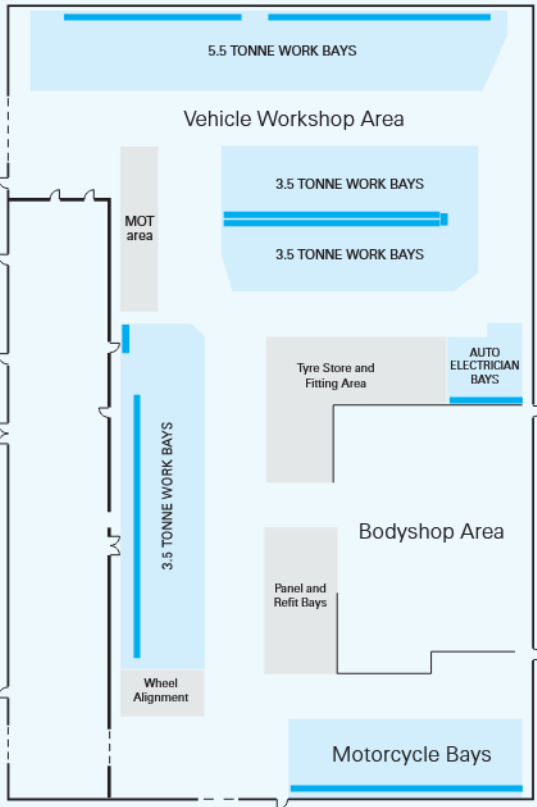
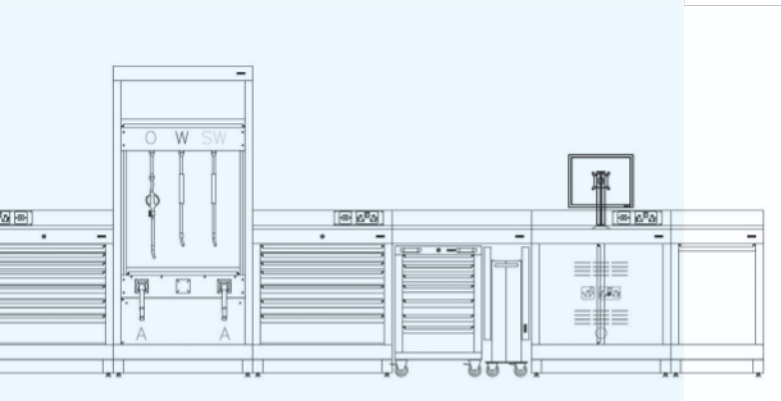

Motorcycle services

THE DESIGN

Working closely with the Metropolitan Police Operational Support Services and Project Manager Alan Crisp, Dura developed a scheme for the development that provided class-leading health and safety standards, while delivering workplace efficiency essential for this time-critical environment.

The facilities needed to accommodate all requirements for the build, repair and maintenance of the service's fleet throughout the entire life-cycle of the vehicles. As a result, every work sector was carefully considered for its specific needs, and the resulting design solutions brought together under a coordinated scheme which unified the workspaces across the entire building. In many places, workstations were planned in continuous runs to maximise tool storage capabilities while safeguarding operator safety. Other areas worked independently but utilised the same system to maintain high-levels of efficiency.

The Motorcycle Workshops provides facilities for complete in-house conversion, build, repair and maintenance. The Body Shop incorporates the latest technology to operate more quickly and in a cleaner way. This helps reduce operating costs and is safer for technicians. Full chassis realignment with unique collision repair capabilities are also included, along with tyre fitting and storage and precise wheel alignment to meet diverse and extreme demands.

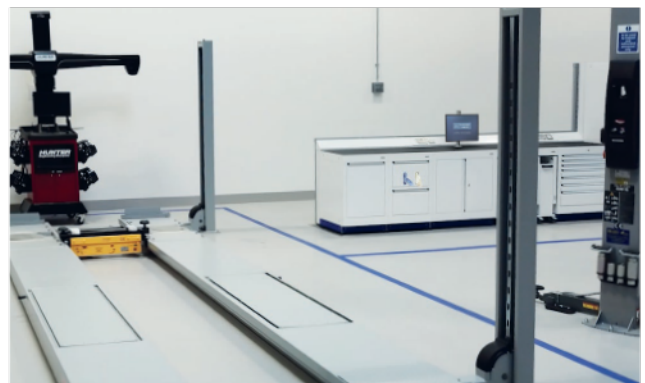

Geometry department



Service bays were carefully designed for their respective uses, from patrol cars to HGVs. All include bay-side fluid dispensing and are fully connected with integrated data points. Vehicle diagnostics connect directly to vehicle manufacturers and there is fully licensed DVSA automated test lane for MOT requirements.

THE RESULTS

Completed on time and on budget, this outstanding facility delivers everything required by a modern and highly reactive police force. Truly a 'Centre of Excellence', these outstanding workshops represent the best of modern policing and provide a vital resource to keep the Met moving and the UK's capital safe.

The complete workshop development was organised by distributor CES's Owner & Project Manager Alan Crisp.



Fixed and mobile solutions





PROJECT NOTES

This project included the following key features

- Dual network and IT integration
- Fixed and mobile tool storage
- Integrated service, air and water
- Modular internal walling system
- Low-level cabinets to improve visibility and communication
- Architectural design installation
- Process-led design



DURA[®]
 Workshop Systems

Dura Limited
 St James Road, Brackley
 Northamptonshire
 NN13 7XY
 tel +44 (0) 1280 700563
 fax +44 (0) 1280 700444
 info@dura.co.uk
 www.dura.co.uk

If you would like to hear more about this
 or similar projects then please call
01280 706050, visit dura.co.uk
 or email info@dura.co.uk



The Queen's
 Awards for
 Enterprise
 International Trade
 2012 winner

